

SYSTEM: STRAINBOX

MODEL: XL



Product description

The StrainBox XL makes it possible to transport critical and defective lithium-ion batteries in an ADR-compliant manner and to store them safely. The size and construction have been specially designed for the storage and transport of batteries and modules, such as those installed in battery electric vehicles.

All packaging in the StrainBox series has an integrated filter system that filters out toxic gases to a large extent. Dust and particles that are harmful to health are retained and the escape of solids, liquids and flames is prevented.

Due to the integrated thermal management, there is no critical temperature increase of the outer walls. If the batteries inside should have an accident, contamination in the vicinity of the packaging is prevented.

To protect people and property, the StrainBox XL also has the typical safety features that only products from Stöbich Brandschutz GmbH offer. These include the filter system, the mechanically resistant design and the integrated thermal management.

Main features

ADR-compliant transport of critical and defective lithium-ion batteries

Retention of liquids and solids

pressure-resistant construction

Secure and stable locking

Integrated gas filter system

Neutralisation of the pollutant gases that occur

mechanical strength

Protection of persons and property

tested complete system

Absorption and dissipation of thermal energy

No escape of sparks and flames

No dusting fillers

Product features

Technical data	StrainBox XL	StrainBox XL3000-M
External dimensions $L_a \times W_a \times H_a$	3.557 x 2.300 x 1.179 mm	
Inner dimensions $L_i \times W_i \times H_i$	2.778 x 2.050 x 770 mm	2.778 x 1.880 x 770 mm
max. empty weight	3.187 kg	3.315 kg
max. payload (transport)	1.583 kg	1.455 kg
max. energy content	125 kWh	
Capacity	4.335 l	2.992 l
Approval	-	approved UN dangerous goods packaging with X-coding for transport in accordance with ADR, RID and IMDG Code*

* Transport modes road, rail, inland and maritime shipping; Stöbich is a manufacturer of dangerous goods packaging with a recognised quality assurance programme in accordance with BAM dangerous goods regulations.

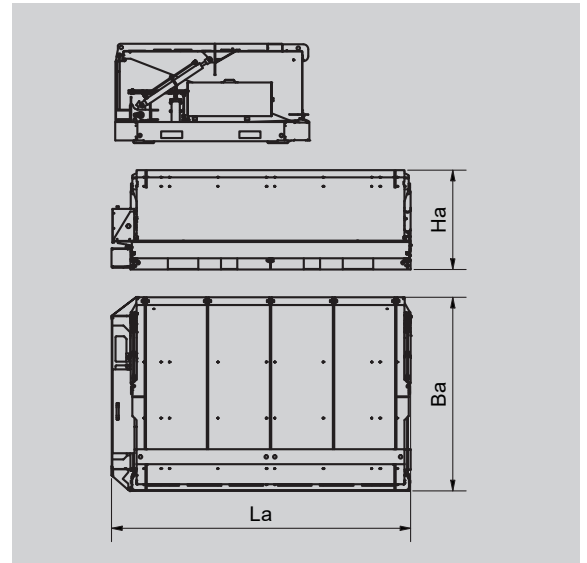

Variants

The StrainBox XL is available with valid approval as dangerous goods packaging. The capacity of this 3000 variant has been reduced to less than 3 m³ for this purpose. The space remains almost completely usable in large parts due to clever partitioning. At the same time, the legal requirements are met. All versions are also available with an electric hydraulic unit. The M variants contain a control unit with cable-connected remote control for this purpose.

Description of the components

- Gas filter system
- Hydraulic cylinder with hydraulic unit
- Electric hydraulic unit (optional)
- Locking system
- Reinforced frame with transport openings

Notes

It is possible to adapt the dimensions to customer requirements after prior consultation.